

Model 207, 212 (except 212.074/075/076/077/092/274/275/276/277/292)

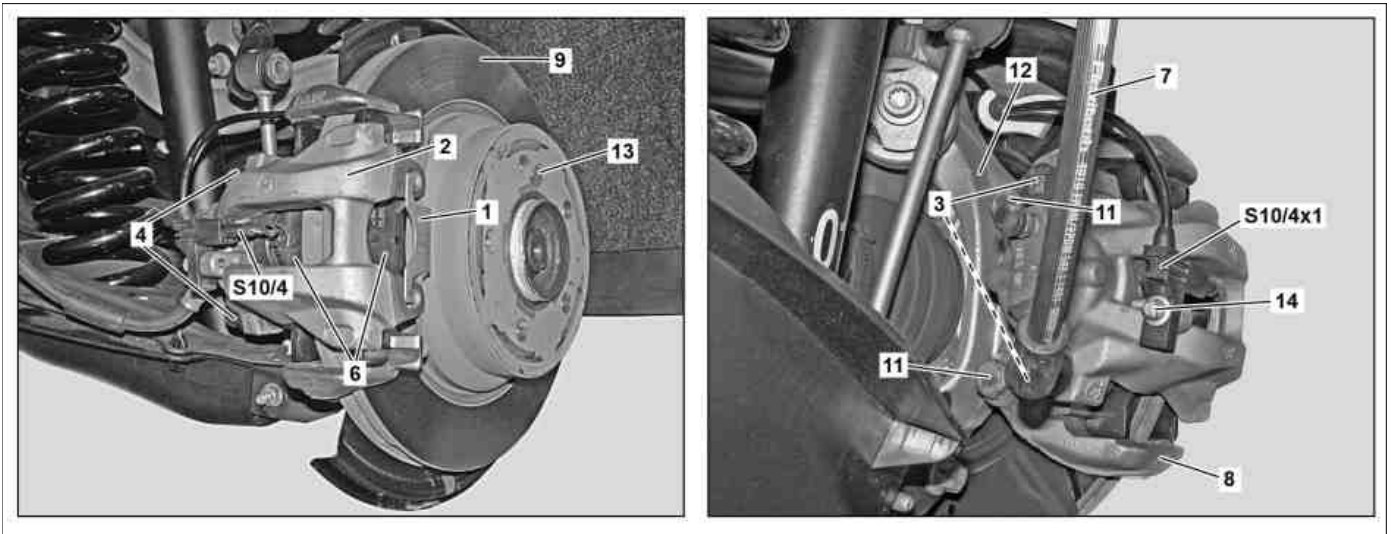

P42.10-2761-08





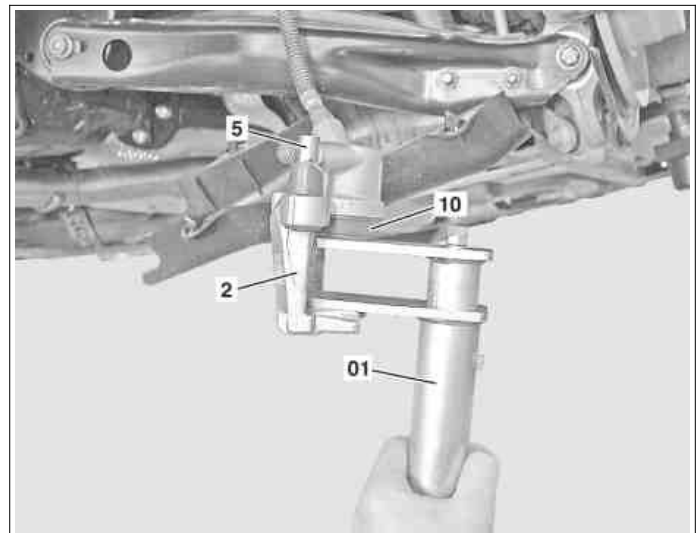











1	Spring	7	Brake hose	13	Locking bolt
2	Brake caliper	8	Caliper support	14	Screw
3	Dust caps	9	Brake disk	S10/4	Right rear brake wear sensor
4	Boots	11	Screw	S10/4x1	Right rear brake wear sensor electrical connector
6	Brake linings	12	Wheel carrier		

01	Pusher tool
2	Brake caliper
5	Guide pin
10	Dust boot



P42.10-2617-11

⚠ Warning	Risk of injury. Skin or eye injuries may result when handling hot or glowing objects.	Wear protective gloves, protective clothing and safety glasses, if necessary.	AS00.00-Z-0002-01A
⚠ Caution	Risk of poisoning from swallowing brake fluid. Risk of injury from skin and eye contact with brake fluid	Only pour brake fluid into suitable and appropriately marked containers. Wear protective clothing and eye protection when handling brake fluid.	AS42.50-Z-0001-01A
	Risk of accident when commissioning the vehicle due to a lack of braking effect when the service brake is operated for the first time after repair work.	Before starting the engine, actuate brake pedal several times until pressure is built up and maintained in the brake system.	AS42.50-Z-0002-01A
	Notes on self-locking nuts and bolts		AH00.00-N-0001-01A
	Notes on repairs to brake system		AH42.00-P-0003-01A
	Brake fluid notes		AH42.50-P-0001-01A

	Notes on installing brake wear indicator contact sensors		AH42.10-P-0003-01CW
	Notes on safety-relevant components		AH00.00-Z-0019-01A
	Remove/install		
1	Clean area surrounding the cap of the brake fluid expansion reservoir	Assembly cleaner	*BR00.45-Z-1028-04A
2	Unscrew cap from brake fluid expansion reservoir and extract some brake fluid	 This prevents the brake fluid expansion reservoir from overflowing when the brake pistons are pushed back.	
3  	Remove rear wheel	Model 207 Model 212 (except 212.074/075/076/077/092/274/275/276/277/292)	AP40.10-P-4050CW AP40.10-P-4050EW
4	Detach spring (1) from brake caliper (2)		
5	Detach rear right brake wear sensor electrical connector (S10/4x1) from coupling housing of rear right brake wear sensor (S10/4)	When removing brake caliper (2) at right.	
6	Remove bolt (14) and place coupling housing of the rear right brake wear sensor (S10/4) to one side	When removing brake caliper (2) at right.  Screw/bolt, brake wear sensor to brake caliper	*BA42.10-P-1003-12J
7	Remove brake hose (7)		AR42.10-P-0013EW
8	Use suitable plug to seal opening on brake caliper (2)	 Record plug	*129589009100
9	Remove dust caps (3) from boots (4)		
10	Unscrew guide pins (5)	 Guide pin to brake caliper support or bolt for guide pin to brake caliper	*BA42.10-P-1004-12J
11	Remove brake caliper (2) from brake caliper support (8)	 Installation: The new brake caliper (2) is shipped in prefilled condition and it may not be drained. Otherwise, the brake caliper (2) cannot be vented.	
12	Remove brake linings(6)		AR42.10-P-1710EW
	Check		
13	Check brake caliper (2) and dust boot (10) on brake piston for leak tightness and damage	If there are problems ↓ Replace brake caliper (2).	
14	Remove stop plug from brake caliper (2)	 Make sure that the brake caliper (2) is not completely emptied. Otherwise, the brake caliper (2) cannot be vented.  Record plug	*129589009100
15	Push back brake piston using pusher tool (01)	When reusing brake caliper (2).  Make sure that the brake caliper (2) is not completely emptied. Otherwise, the brake caliper (2) cannot be vented.  Collect escaping brake fluid in a suitable container.  Resetting device If brake piston is sluggish ↓ Replace brake caliper (2).	*000589524300
16	Use suitable plug to seal opening on brake caliper (2) again	 Record plug	*129589009100
17	Check boots (4) on brake caliper (2) for damage	If there are problems ↓ Replace boots (4).	
18	Check brake caliper support (8) for damage	If there are problems ↓ Replace brake caliper support (8).  Bolt, brake caliper/brake caliper support to wheel carrier	*BA42.10-P-1001-12J
19	Check brake disk (9) for wear and that it is in good condition		

AP		Model 207 Model 212 (except 212.074/075/076/077/092/274/275/276/277/292) except code B07 (Ceramic brake system) If there are problems ↓ Install new brake disks (9). Model 207 Model 212 (except 212.074/075/076/077/092/274/275/276/277/292) except code B07 (Ceramic brake system)	AP42.10-P-4258EW AR42.10-P-0220EWE
20	Clean contact surfaces of brake linings (6) on brake caliper (2) and on brake caliper support (8)	ⓘ Do not damage dust boot (10) on the brake piston. Otherwise, the brake caliper (2) could be damaged. Assembly cleaner	*BR00.45-Z-1028-04A
21	Install in the reverse order		
22	Bleed brake system		AR42.10-P-0010EW
23	Depress brake pedal several times until brake linings (6) rest against brake disks (9)	ⓘ Firm resistance should be noticeable at the brake pedal.	
◀	Check		
24	Check and correct brake fluid level in expansion reservoir for brake fluid		AP42.10-P-4210EW
AP	25	Carry out brake test on the test stand	AP42.00-P-4290BA

Nm Rear axle brake caliper

Number	Designation		Model 207	Model 212
BA42.10-P-1001-12J	Bolt, brake caliper/brake caliper support to wheel carrier	Nm	115	135

Nm Rear axle brake caliper

Number	Designation		Model 207	Model 212
BA42.10-P-1003-12J	Screw/bolt, brake wear sensor to brake caliper	Nm	8	8

Nm Rear axle brake caliper

Number	Designation		Model 207	Model 212
BA42.10-P-1004-12J	Guide pin to brake caliper support or bolt for guide pin to brake caliper	Nm	25	25

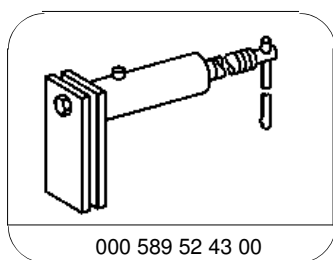

Resetting device

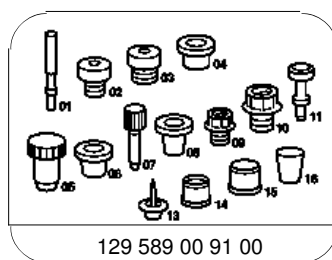

Record plug

Repair materials

Number	Designation	Order number
BR00.45-Z-1028-04A	Assembly cleaner	Adolf Würth GmbH & Co. KG Reinhold-Würth-Str. 12-17 74653 Künzelsau-Gaisbach Germany Tel. +49 7940 15-0 Fax +49 7940 15-1000 http://www.wuerth.de