

Repair materials

Number	Designation	Order number
BR00.45-Z-1028-04A	Cleaner from package	Adolf Würth GmbH & Co. KG Reinhold-Würth-Str. 12-17 74653 Künzelsau-Gaisbach Germany Tel. +49 7940 15-0 Fax +49 7940 15-1000 www.wuerth.de

i The brake caliper does not need to be detached from the brake hose when the guide sleeve is replaced.

i The repair kit consists of guide sleeves with protective caps, seal boots and repair grease. Each brake caliper requires one repair kit.

Removing

- 1 Clean brake caliper (1) with LU cleaner.
- 2 Press guide sleeve (2) and seal boot (3) outwards.
- 3 Lever seal boot (3) out of radial groove (4) and push back over guide sleeve (2) toward brake caliper (1).
- 4 Using a suitable tool, press guide sleeve (2) out of housing bore (5) of brake caliper (1) from inside outward.

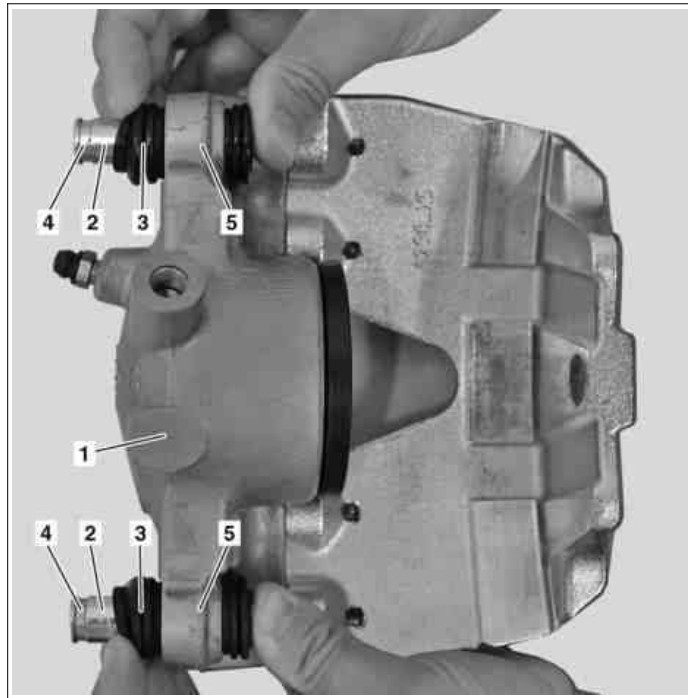

P42.10-2636-12

- 5 Pull seal boot (3) out of housing bore (5) of brake caliper (1).
- 6 Clean inside area of the housing bore (5) with LU cleaner and check for damage and wear.
 - w** The inside surface must not be processed using tools (or similar) which remove material, otherwise the inside surface will be damaged.
 - i** If wear due to corrosion or ridging is evident on the inside surface, the brake caliper (1) must be replaced.

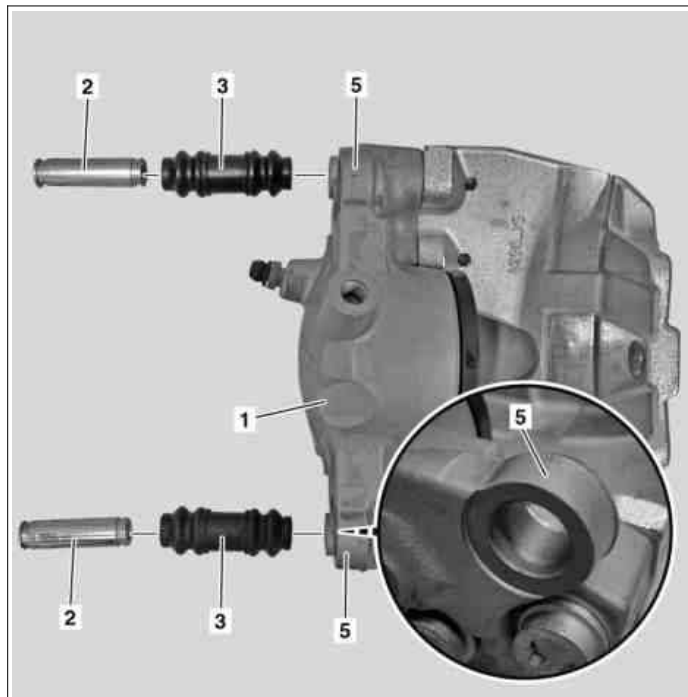

P42.10-2637-12

Install

- 7 Fill the grooves of the seal boot (3) with approx. 2 grams of repair grease.
 - ⓘ The seal boot (3) must not be filled with too much repair grease, otherwise the guide sleeve (2) may not be able to move properly in the seal boot (3).
- 8 Push seal boot (3) onto guide sleeve (2) just past radial groove (4).
- 9 Push preassembled seal boot (3) with guide sleeve (2) into housing bore (5) of brake caliper (1).



P42.10-2638-12

- 10 Insert guide sleeve (2) into housing bore (5) from inside outward.
 - ⓘ Make sure that the seal boot (3) is seated correctly in the radial grooves (4, 7), otherwise the repair grease can escape.
- 11 Move the guide sleeve (2) to and fro several times (arrow).
 - ⓘ In order to ensure that the repair grease is distributed evenly in the sliding zone of the guide sleeve (2).
- 12 Using a suitable tool, detach protective caps (6) from guide sleeve (2).
 - ⓘ Do not use any sharp-edged tool in order to avoid damaging the end face of the guide sleeve (2).
- 13 Check that seal boot (3) is seated correctly by means of visual inspection.
- 14 Clean contact surfaces on end face of guide sleeve (2) using LU cleaner.
 - ⓘ The contact surfaces must be absolutely free from grease and dirt otherwise the bolts may shear when tightening to the specified torque.